

Research in Virtual Oscillator Controls for Microgrids at NREL

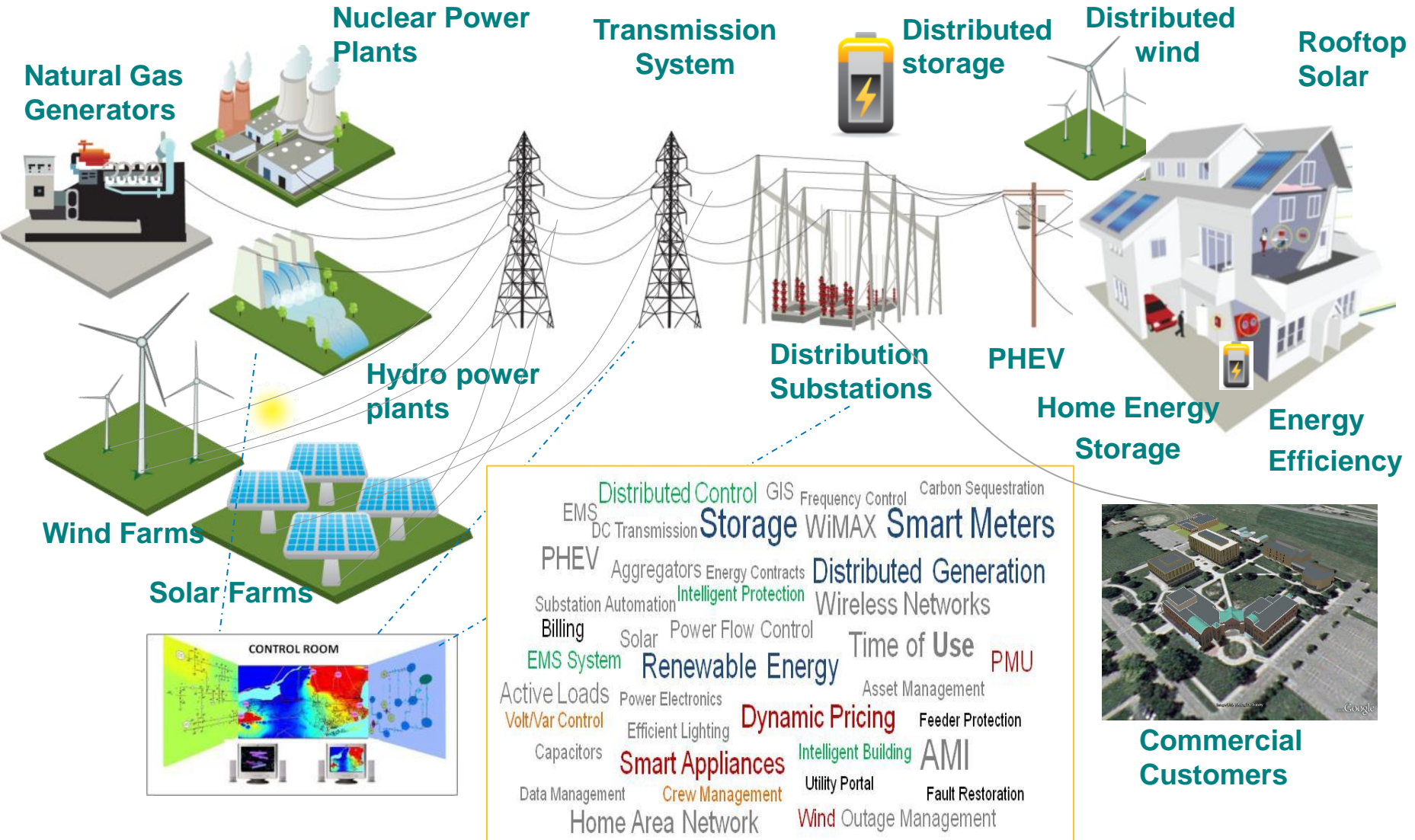

James Cale, Ph.D., Group Manager
Distributed Energy Systems Integration (DESI)
Power Systems Engineering Center
National Renewable Energy Laboratory

The Emerging Grid



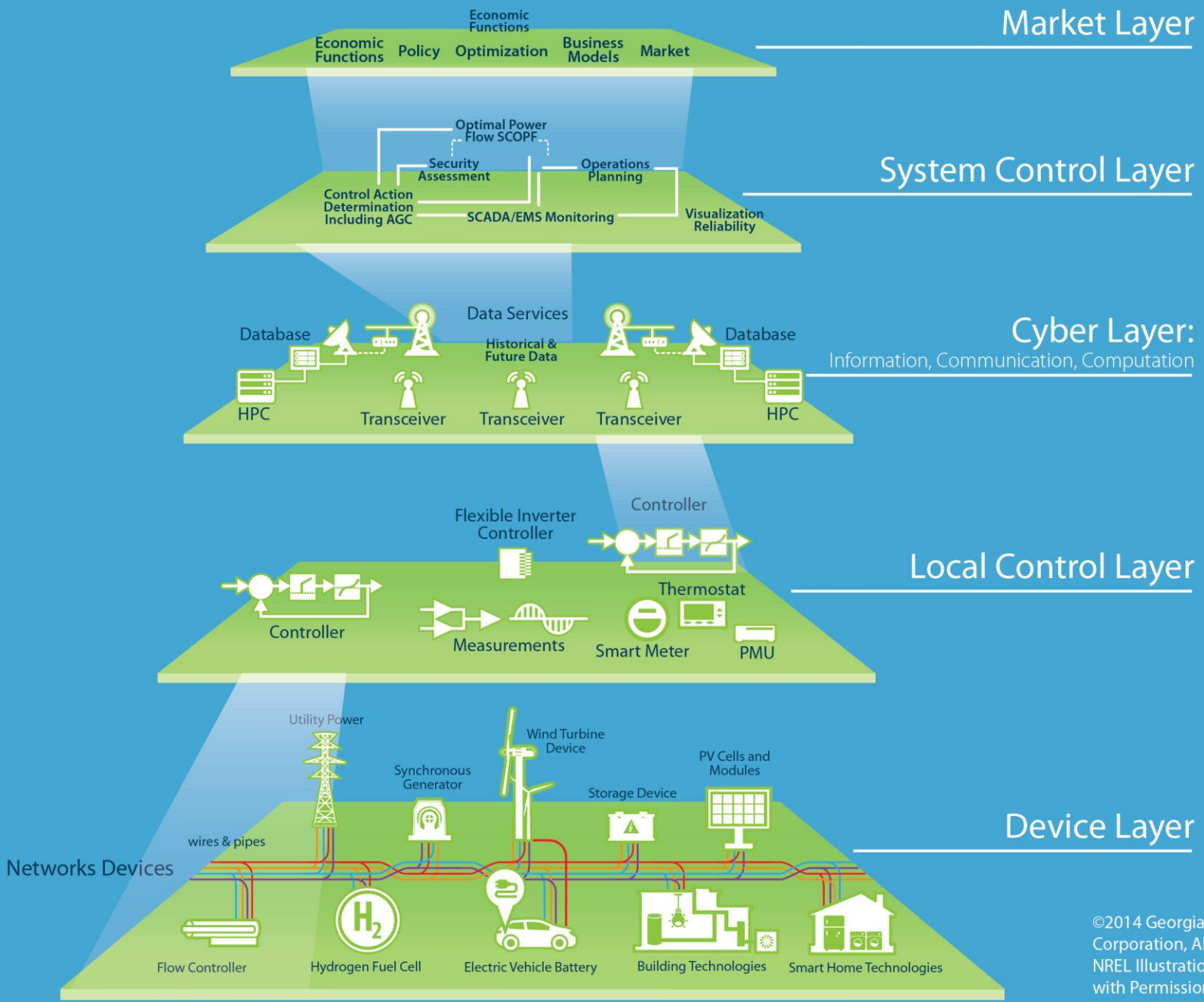

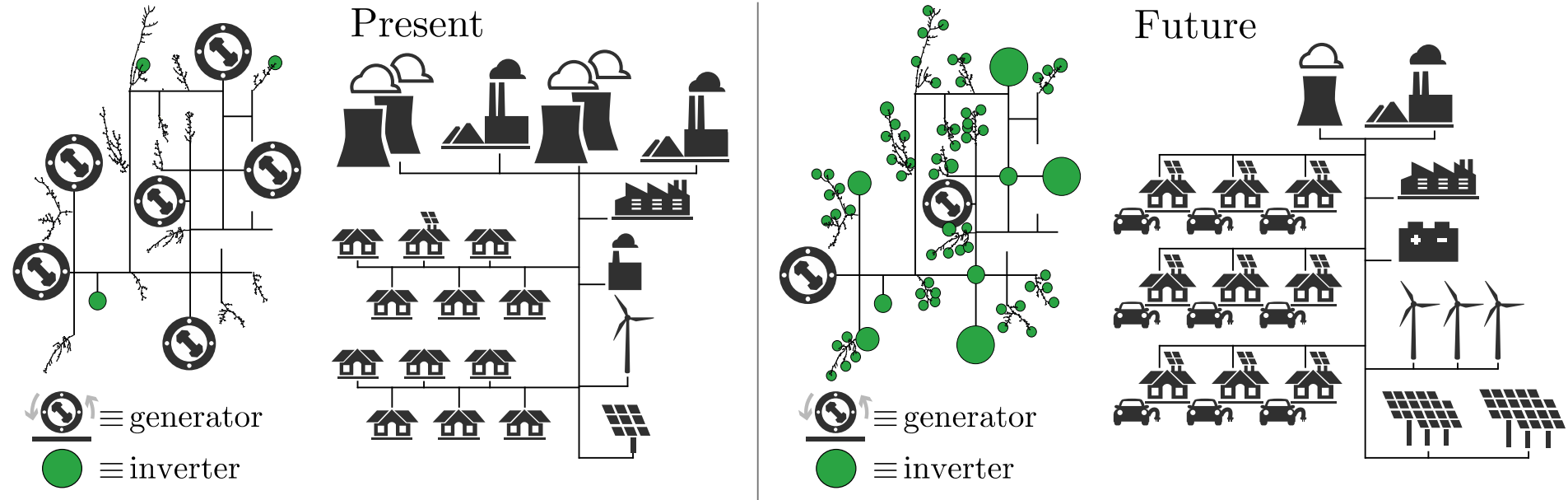

Synchronization in Nature

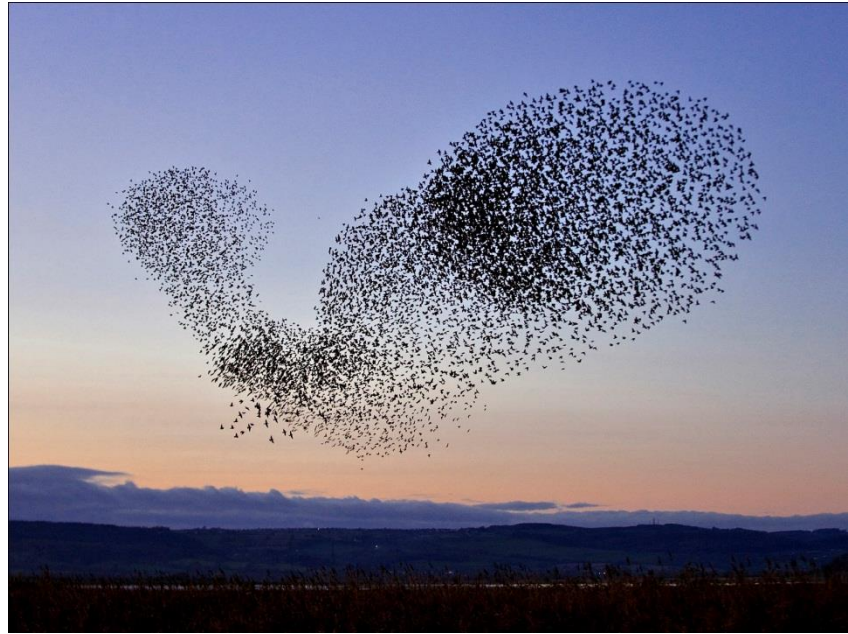

Control for Distributed Energy Resources

Dc Sources



PV



EV Battery

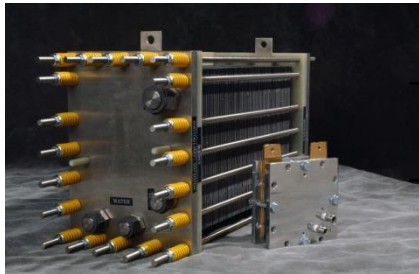

Fuel Cells

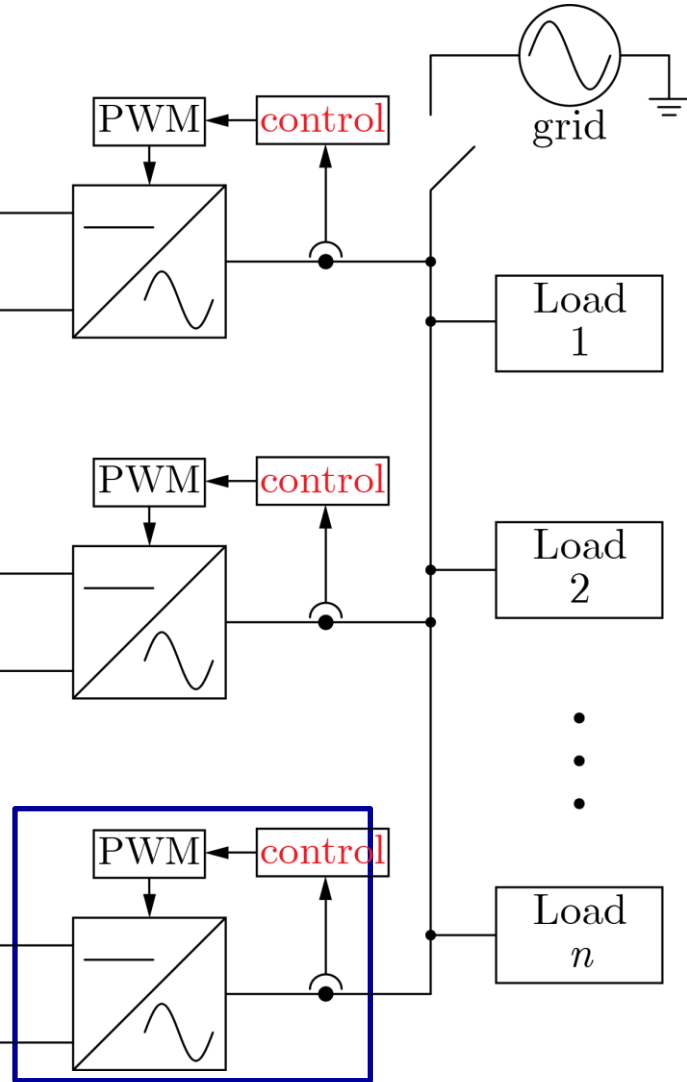

Challenges:

- Low-inertia
- Minimize communication
- Plug and play
- Intermittency
- Reliability
- Multi-mode operation

Building Block:
Inverter

Digital Control

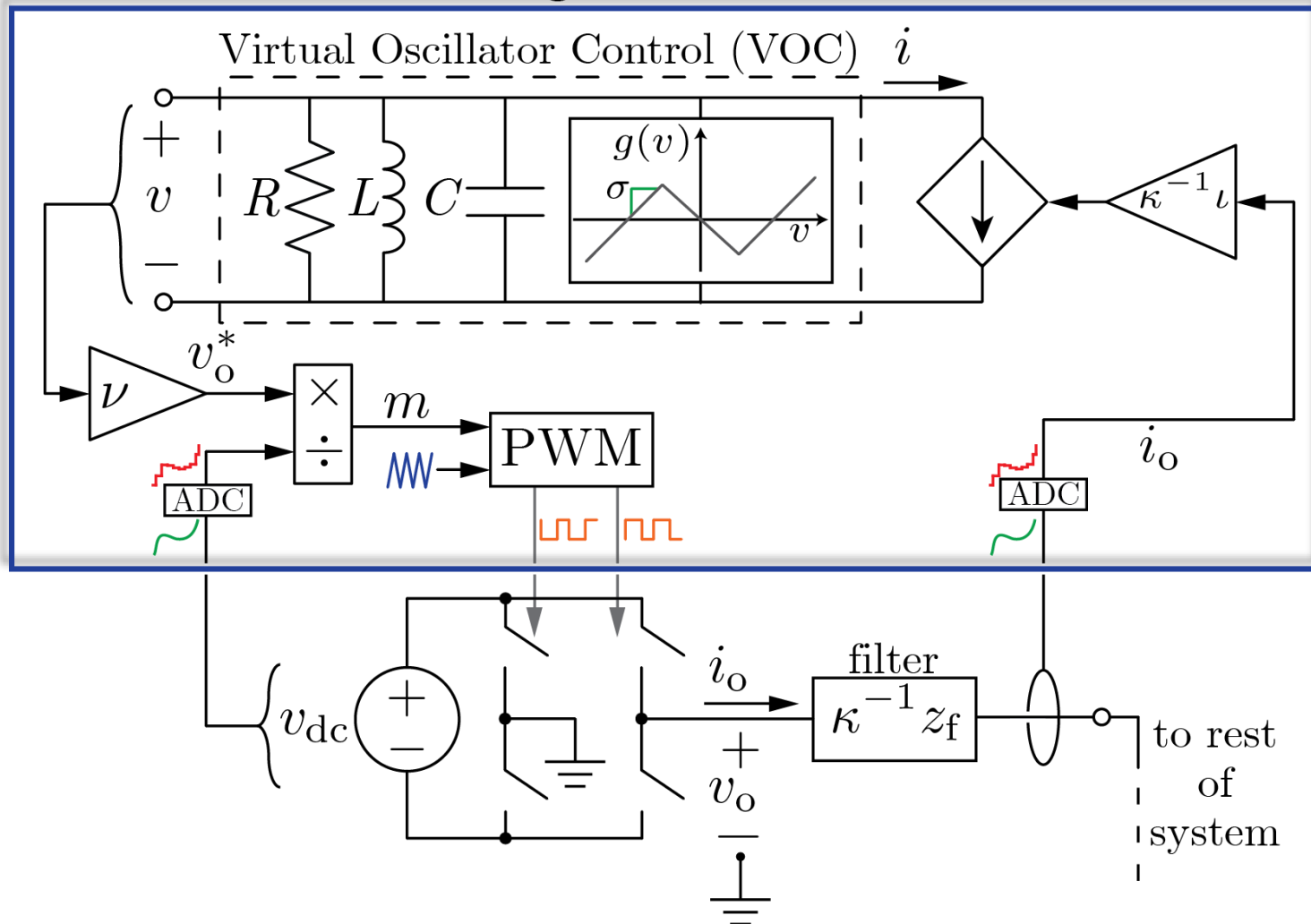

micro-
controller



010010100110
110110101011
100101010001

power
electronics

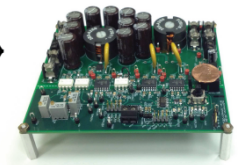

Experimental Results

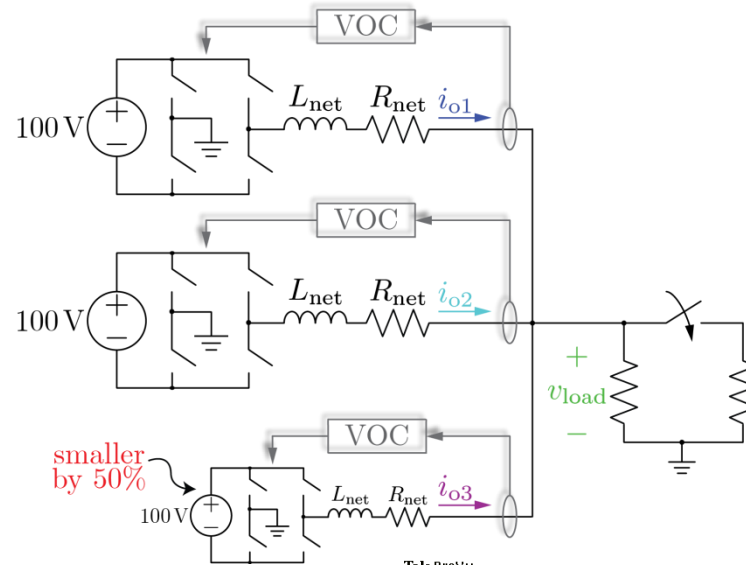

experiment

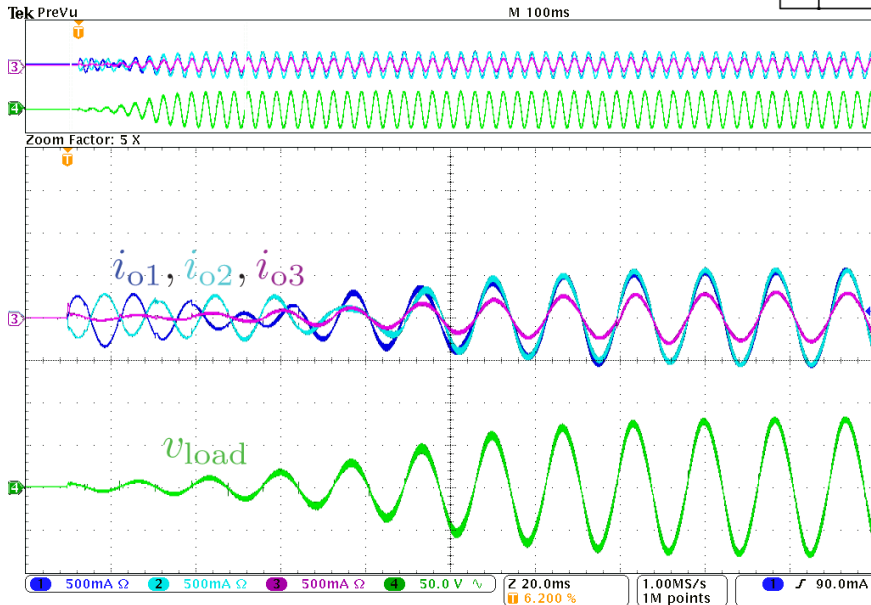

Startup

14 Dec 2012
10:15:50

experiment

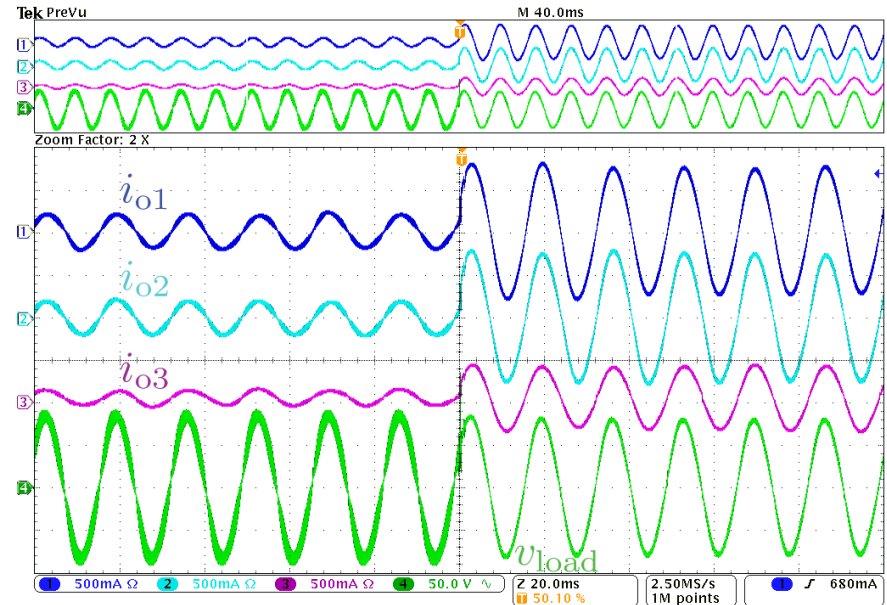

Load Step Up

13 Dec 2012
10:48:17

Replication at Scale: Microgrid at ESIF

Rooftop PV & Wind



Energy Storage Lab
Residential, Community
& Grid Battery Storage,
Flywheels & Thermal

Smart Power Lab
Buildings & Loads

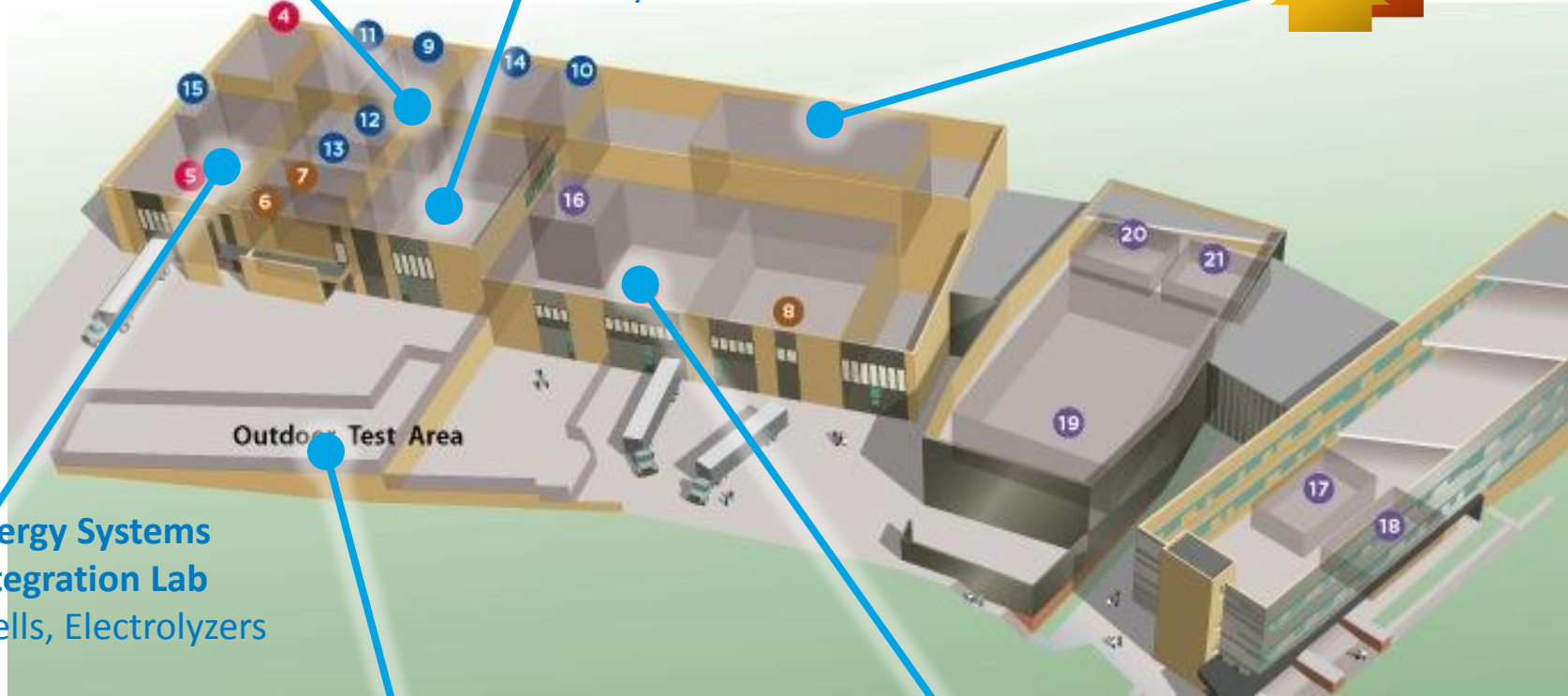

Energy Systems
Integration Lab
Fuel Cells, Electrolyzers

Outdoor Test Area

Outdoor Test Area
EVs, Power Transformers



Power Systems
Integration Lab
PV Simulator



MW Scale Hardware-in-the-Loop

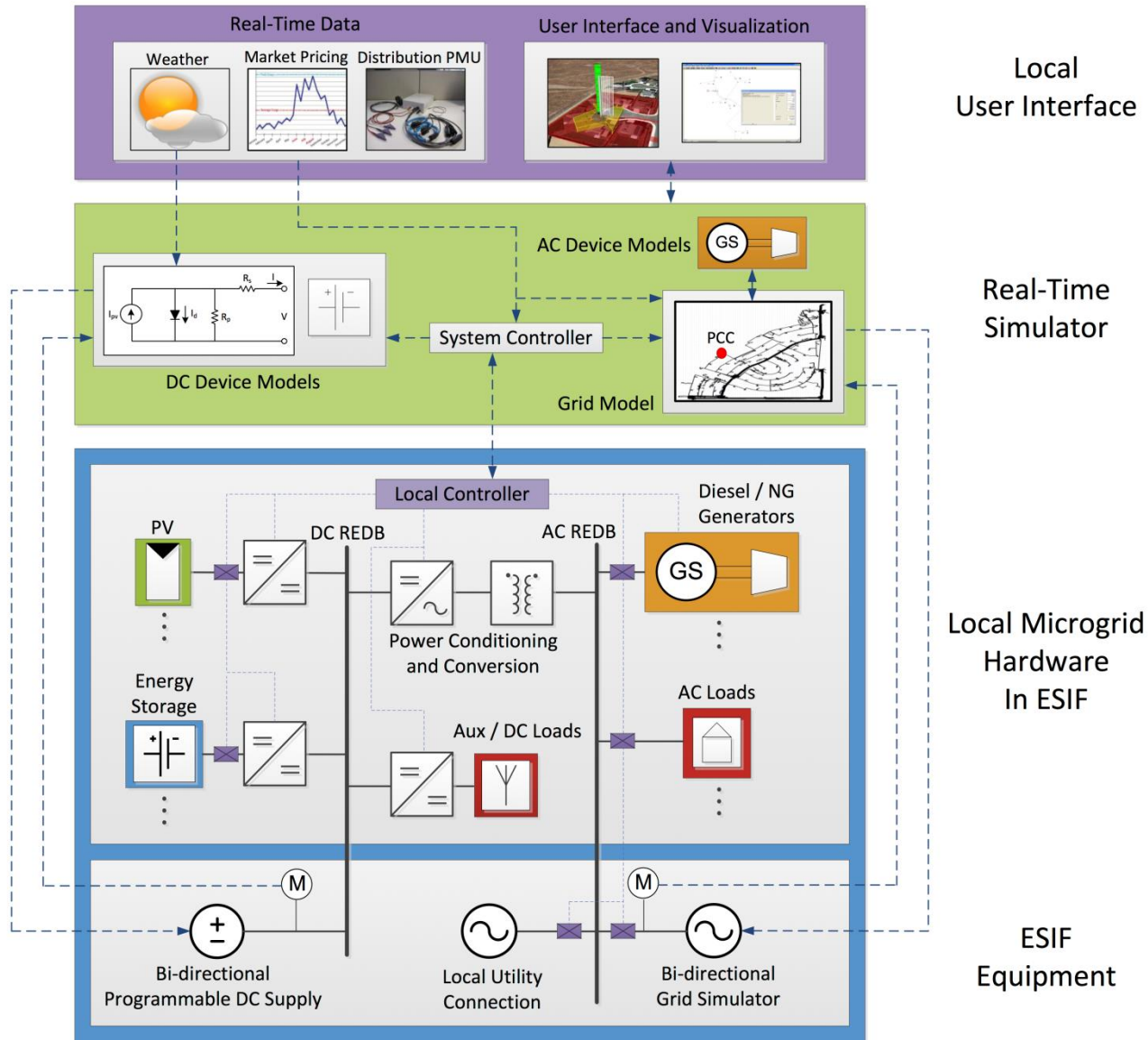

Thank You!!

James Cale, Ph.D.

Manager, Distributed Energy Systems Integration

(303) 384-7923

james.cale@nrel.gov

